

ADDENDUM NO. 1

TO: PLANS AND SPECIFICATIONS FOR STATE OF MISSOURI

**Renovate Interior/Exterior Barns 39, 40, & 41
Missouri State Fairgrounds
Sedalia, Missouri
PROJECT NO. F2404-01**

Bid Opening Date is: 1:30 PM, Tuesday, April 1st, 2025

Bidders are hereby informed that the Construction Plans and/or Specifications are modified as follows:

SPECIFICATION CHANGES:

1. Section 011000 1.3.A.1
 - a. REVISE as follows:
 - i. "Work affecting use of barns that is started prior to 2025 State Fair must be completed by July 31, 2025."
2. Section 012200 1.2.3
 - a. DELETE
3. Section 013200 3.1.A.1
 - a. ADD d. as follows:
 - i. Unit prices as described in section 012200, to include base bid amounts are to be listed within the schedule of values.

DRAWING CHANGES:

1. SHEET A401
 - a. ADD attached detail AD 1.3
2. SHEET A508
 - a. ADD attached detail AD 1.2
3. SHEET A601
 - a. REPLACE "WINDOWS" detail with updated detail AD 1.1

GENERAL COMMENTS:

1. The Pre-Bid Meeting was held March 20, 2025 followed by a walk-through of the site. The Pre-Bid Meeting sign-in sheet is attached.
2. Bidders needing additional site inspection should contact Justin Anderson at 660-317-8740 to schedule a time.
3. Please contact April Howser, Contract Specialist, at 573-751-0053 or april.howser@oa.mo.gov, for questions about bidding procedures and MBE\WBE\SDVE goals and submittal requirements.
4. The deadline for technical questions is 5pm on March 24, 2025.
5. Changes to, or clarification of, the bid documents are only made as issued in the addenda.

6. All correspondence with respect to this project must include the State of Missouri project number as indicated above.
7. Current Planholders list available online at:
<https://www.oafmdcplanroom.com/projects/2804/plan-holders/f2404-01-renovate-interior-exterior-barns-39-40-41-missouri-state-fairgrounds>
8. Prospective Bidders contact American Document Solutions, 1400 Forum Blvd Suite 1C, Columbia MO 65201, 573-446-7768 to order official plans and specifications.

ATTACHMENTS:

1. Pre-bid Sign in Sheet
2. Detail AD 1.1
3. Detail AD 1.2
4. Detail AD 1.3

March 21, 2025

END ADDENDUM NO. 1

**Pre-Bid Meeting Attendance Sheet
Renovate Interior/Exterior, Barns 39, 40, & 41
Missouri State Fairgrounds
Sedalia, MO**

**Project No. F2404-01
3/20/25**

Name & Title	Company Name Type of Contracting	MBE/WBE/ SDVE Status	Phone	E-Mail Address
Jared Cook	OA-FMDC		573.690.6733	Jared.cook2@oa.mo.gov
Dustin Cooper	OA-FMDC			Dustin.cooper@oa.mo.gov
Justin Anderson	MSF			Justin Anderson@mda.mo.gov
Jason Moore	MSF			Jason.moore@mda.mo.gov
Aaron Kennedy	Robert Rollings Architects		660.829.9751	aaron@rollingsarchitects.com

Pre-Bid Meeting Attendance Sheet
Renovate Interior/Exterior, Barns 39, 40, & 41
Missouri State Fairgrounds
Sedalia, MO

Project No. F2404-01
3/20/25

Name & Title	Company Name Type of Contracting	MBE/WBE/ SDVE Status	Phone	E-Mail Address
Justin Rogers PM	Brown & Root GC		573 301 4995	Justin.Rogers@ BrownandRoot.com
DAN START OWNER	START INC MASONRY		314-743-0629	DAN@STARTINC.COM
Bret Palliser President	G+R Construction Inc		573-289-9401	Bretp@grcon.org
Jasen Sparks Super Brandon Dorde P.M.	Missouri Builders Service		660-281-2212 573-298-2338	bdorge@missouribuilders.net
Bill Anderson Estimator	BTP Excavating		660-827-1385	bpexc205@iland.net

Pre-Bid Meeting Attendance Sheet
Renovate Interior/Exterior, Barns 39, 40, & 41
Missouri State Fairgrounds
Sedalia, MO

Project No. F2404-01
3/20/25

Name & Title	Company Name Type of Contracting	MBE/WBE/ SDVE Status	Phone	E-Mail Address
Tom Lendox	PROPROST	X	573-645-06975	ESTIMATING@PROSTBUILDERS.com
Bill Croll	All-spec metal Systems		573-896-5909	bill.croll@specms.com
Aaron Forck	BAC Local 15		816-308-9594	aaronforck@baclocal15.org
John Oke-Thomas	OKE-THOMAS	MBE	417-863-6262	JOHN@OKE-THOMAS.COM
Reed McCollester	MCCOLLESTER CONSTRUCTION		660-620-2546	REED@MCCOLLESTERCONSTRUCTION.COM

**Pre-Bid Meeting Attendance Sheet
Renovate Interior/Exterior, Barns 39, 40, & 41
Missouri State Fairgrounds
Sedalia, MO**

**Project No. F2404-01
3/20/25**

Name & Title	Company Name Type of Contracting	MBE/WBE/ SDVE Status	Phone	E-Mail Address
Kevin Teague Owner	W&M Services Steel Cont.		660-826-3705	Kevin@wmwelding.com
Tamra Stallman owner	Precision Demolition Demo	WBE/ SLBE DBE	816-215-0827	Tamra@precisiondemo.org
Wayne Loftin Project Manager	MTS Contracting		816-918-3279	Wloftin@mtscontracting.com
Mike Mann PM	IM Restoration		816-841-7455	mike@imrestoration.com
DAVEN SANDERS PM	SEPTAGON		660-827-5955	dsanders@septagon.com

**Pre-Bid Meeting Attendance Sheet
Renovate Interior/Exterior, Barns 39, 40, & 41
Missouri State Fairgrounds
Sedalia, MO**

**Project No. F2404-01
3/20/25**

Name & Title	Company Name Type of Contracting	MBE/WBE/ SDVE Status	Phone	E-Mail Address
Chace Larson PM	Sub Craftsman Painting	WBE	660 217 2049	Chace@craftsmanpaintingllc.com
Greg Ford PM	Reinhold Electric		314 714 0426	GFORD@reinholdelectric.com
Jordan Grisham Pm	All Spec Metals		573-280-9650	jordan@allspecms.com
KENT EICHMOLZ	ASSOCIATED DOOR COMPANY		(660) 826-2968	Kent@associateddoor.com
Rhod Baker	Rhod Baker Const		573-489-6470	rhod_baker@yahoo.com
John Hunte Brett Fickle	Westport Construction		660-885-2231	Westport@wccmo.com

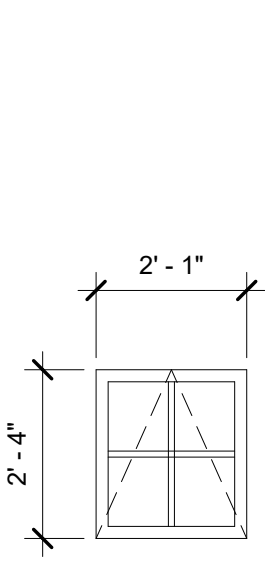

A

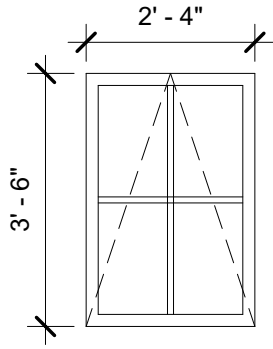

B

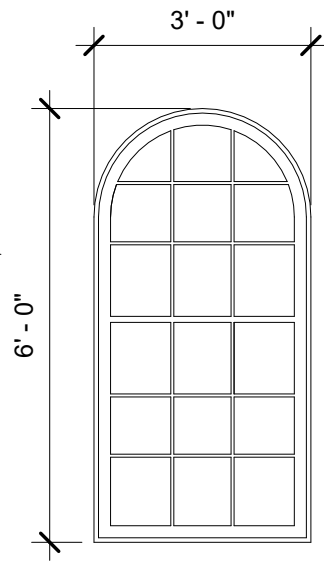

C

VERIFY ALL DIMENSIONS AND QUANTITIES

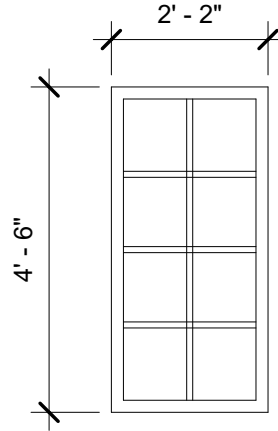

D

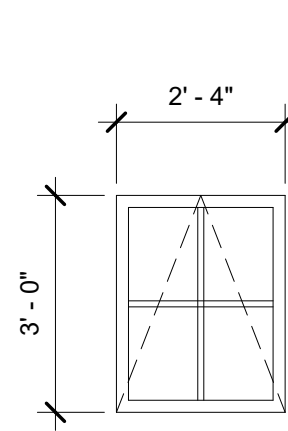

E

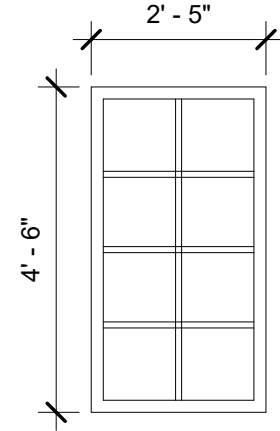

F

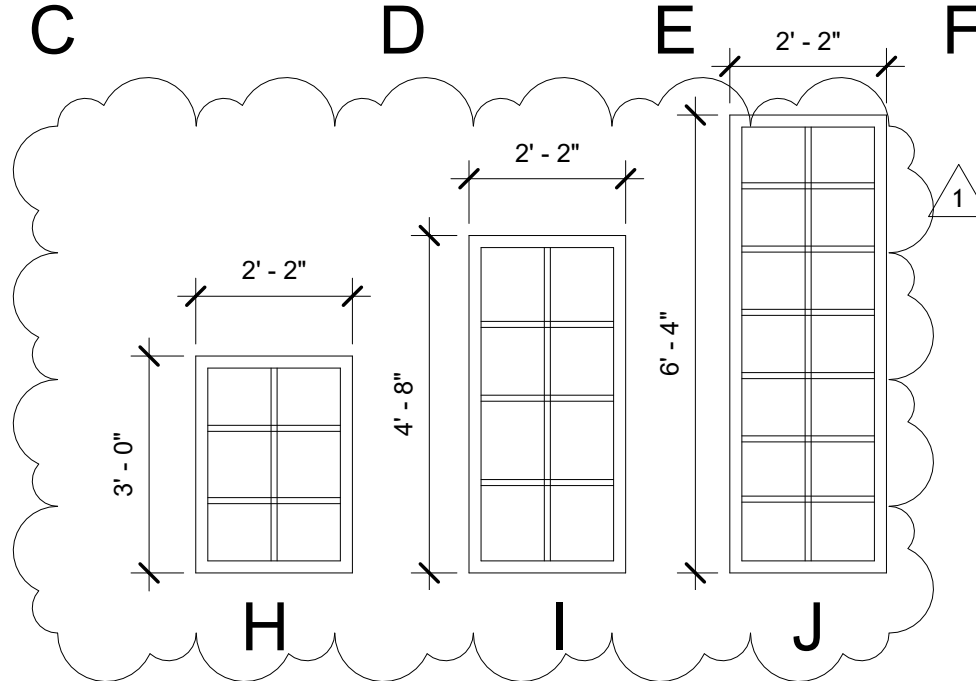

H

I

J



COPYRIGHT © 2025

F2404 RENOVATE INTERIOR, & EXTERIOR,
 BARNs 39, 40, & 41
 2503 W. 16TH ST. SEDALIA, MO 65301

DATE 03/19/25

PROJECT NO. 60.158

DRAWING NO.

AD1.1

DESCRIPTION:

DWG REF: XXXX

WINDOW
 SCHEDULE



REPAINT ALL CONCRETE
BUMPERS. BUMPERS OCCUR
ONLY ON BARNs 39 & 41, TYP.



COPYRIGHT © 2025

F2404 RENOVATE INTERIOR, & EXTERIOR,
BARNs 39, 40, & 41

2503 W. 16TH ST. SEDALIA, MO 65301

DATE 03/19/25

PROJECT NO. 60.158

DRAWING NO.

AD1.2

DESCRIPTION:

DWG REF: XXXX

PAINT BUMPERS

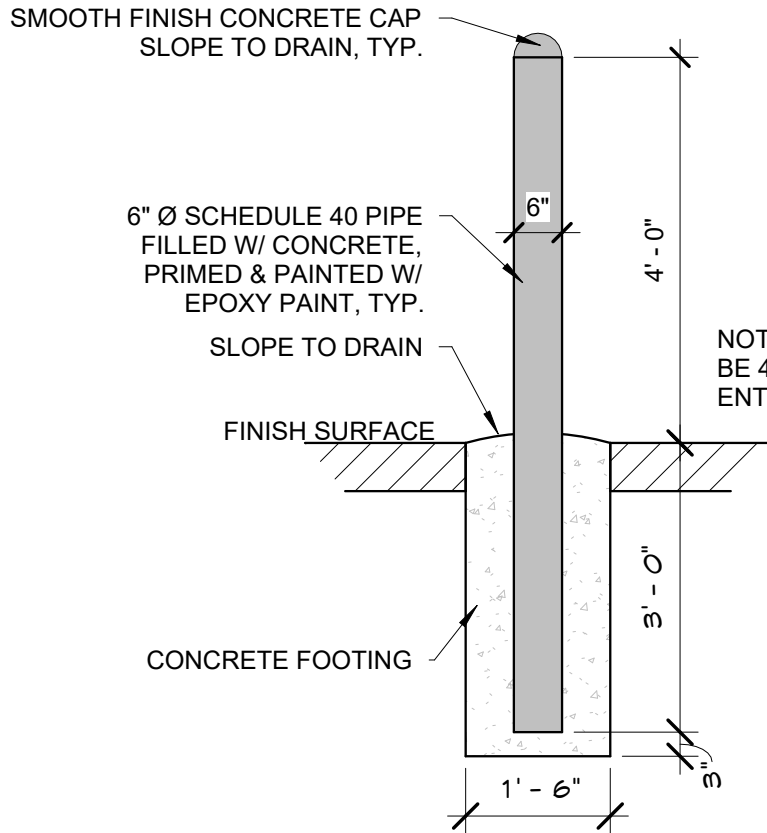

1	BOLLARD DETAIL
AD1.3	1/2" = 1'-0"

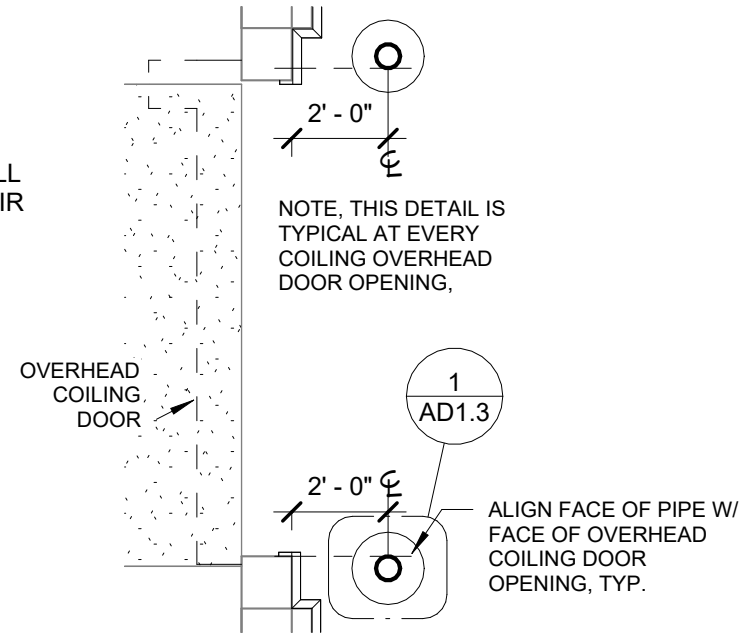

2	BOLLARD PLACEMENT
AD1.3	1/4" = 1'-0"



COPYRIGHT © 2025

F2404 RENOVATE INTERIOR, & EXTERIOR,
BARN 39, 40, & 41
2503 W. 16TH ST. SEDALIA, MO 65301

DESCRIPTION:

DATE 03/19/25

PROJECT NO. 60.158

DWG REF: XXXX

DRAWING NO.

AD1.3

BOLLARDS