

ADDENDUM NO. 2

TO: PLANS AND SPECIFICATIONS FOR STATE OF MISSOURI

**Replace Five Basic Sites with Five Premium Yurts
Table Rock State Park
Branson, Missouri
PROJECT NO.: X2215-01**

Bid Opening Date: 1:30 PM, Thursday, May 4, 2023 (Not Changed)

Bidders are hereby informed that the construction Plans and/or Specifications are modified as follows:

SPECIFICATION CHANGES:

1. Section 011000 – Summary of Work
 - a. REVISE Paragraph 1.4-B.1 as follows:
 1. Owner Occupancy: Allow for Owner occupancy and use by the public. Existing yurt will be occupied during construction. Daytime construction activities will be allowed by the Contractor in the area of the existing yurt between the hours of 9:00 AM – 5:00 PM.
 - b. REVISE Paragraph 1.6-A as follows:
 - A. The Owner will furnish fire rings, lantern posts, and pre-assembled picnic tables. These items will be Owner provided and Contractor installed.
2. Section 071113 – Bituminous Dampproofing
 - a. REVISE Paragraph 2.01-B by adding the following acceptable manufacturer:
 5. Carlisle Coatings and Waterproofing – Barricoat
3. Section 072726 – Fluid Applied Membrane Air Barriers
 - a. REVISE Paragraph 2.2-A.1 by adding the following acceptable manufacturer:
 - e. Carlisle Coatings and Waterproofing – Barritech VP
4. ADD new specification Section 133130 – Cable Supported and Tension Fabric Structures (attached).
5. ADD new specification Section 321216 – Asphalt Paving (attached).
6. DELETE specification Section 330523 – Trenchless Utility Installation in its entirety. Directional drilling is not allowed.

DRAWING CHANGES:

1. Sheet C-101
 - a. REVISE Note 10 as follows: No open cutting of concrete driveways is allowed. All utilities beneath concrete driveways shall be bored.
 - b. ADD Note 11 as follows: Asphalt roadway may be either bored (Spec. Section 330523.16) or open-cut (see detail sheet C-503) at Contractors discretion.
2. Sheet C-102 (attached)
 - a. ADD 2" mill and 2" BP-1 overlay notes.
3. Sheet C-103 (attached)
 - a. ADD 2" mill and 2" BP-1 overlay notes.
4. Sheet C-105
 - a. REVISE bottom left NOTE as follows: Water and sewer utilities beneath asphalt pavement may be either bored or open-cut trenched. Utilities beneath concrete driveways must be bored.
5. Sheet C-106
 - a. REVISE NOTE as follows: Water and sewer utilities beneath asphalt pavement may be either bored or open-cut trenched. Utilities beneath concrete driveways must be bored.
6. Sheet C-503 (attached)
 - a. ADD UTILITY TRENCH WITH OVERLAY DETAIL.
7. Sheet C-504
 - a. DELETE reference to proprietary provider, E/ONE MODEL DH071-74, from TYPICAL LOW PRESSURE LATERAL & GRINDER PUMP INSTALLATON DETAIL.
8. Sheet C-505
 - a. DELETE ROAD EDGE FINISH DETAIL.
9. Sheet A-201
 - a. ADD the following to NOTE: See Specification Section 133130 – Cable Supported and Tension Fabric Structures for approved yurt manufacturers.
10. Sheet A-402
 - a. REVISE Details 3/A-402 and 4/A-402 Millwork notes to Solid Knotty Pine, square raised shape, clear finish.

GENERAL COMMENTS:

1. Please contact Paul Girouard, Contract Specialist, at 573-751-4797 or paul.girouard@oa.mo.gov for questions about bidding procedures, MBE\WBE\SDVE Goals, and other submittal requirements.
2. The deadline for technical questions was Wednesday, April 27, 2023 at noon (12:00 PM).
3. Changes to, or clarification of, the bid documents are only made as issued in the addenda.
4. All correspondence with respect to this project must include the State of Missouri project number as indicated above.
5. Current Plan holders list available online at <https://www.oafmdcplanroom.com/jobs/1799/details/x2215-01-replace-five-basic-sites-with-5-premium-yurts-table-rock-state-park>
6. Prospective Bidders contact American Document Solutions, 1400 Forum Blvd Suite 1C, Columbia MO 65201, 573-446-7768 to order official plans and specifications.
7. **All bids shall be submitted on the bid form without additional terms and conditions, modifications, or stipulations. Each space on the bid form shall be properly filled including a bid amount for each alternate. Failure to do so will result in rejection of the bid.**
8. **MBE/WBE/SDVE participation requirements can be found in DIVISION 00. The MBE/WBE/SDVE participation goals are 10%/10%/3%, respectively. Only certified firms as of the bid opening date can be used to satisfy the MBE/WBE/SDVE participation goals for this project. If a bidder is unable to meet a participation goal, a Good Faith Effort Determination Form must be completed. Failure to complete this process will result in rejection of the bid.**
9. **The Contractor shall pay not less than the prevailing hourly rate of wages for work of a similar character in the locality in which the work is performed, as determined by the Missouri Department of Labor and Industrial Relations.** Bidders are to adhere to Prevailing Wage Hourly Rate of Wages and the Department of Labor and Industrial Relations can be contacted to determine the applicable wage rate for the work on this project.

ATTACHMENTS:

1. Section 133130 – Cable Supported and Tension Fabric Structures
2. Section 321216 – Asphalt Paving
3. Sheet C-102
4. Sheet C-103
5. Sheet C-503

April 28, 2023

END OF ADDENDUM NO. 2

SECTION 133130 – CABLE SUPPORTED AND TENSION FABRIC STRUCTURES

PART 1 - GENERAL

1.1 SECTION INCLUDES:

- A. Pre-engineered, cable or tension support fabric structure system (herein known as yurt).

1.2 DESIGN REQUIREMENTS:

- A. Verify with all dimensions shown on drawings.
- B. Yurt package shall include standard and optional features listed in specifications.

1.3 SUBMITTALS:

- A. Product data: Manufacturer's catalog data, detail sheets, and specifications.
- B. Shop drawings: Layout and erection drawings showing overall dimensions, cross sections, and trim details, clearly indicating proper assembly.
- C. Samples: Color selection samples consisting of actual fabric material.
- D. Quality assurance/control submittals:
- E. Qualifications: Letter certifying manufacturer's required qualifications.
- F. Structural design calculations.
- G. Manufacturer's installation instructions.

1.4 QUALITY ASSURANCE:

- A. Manufacturer's Qualifications: Minimum of five years experience in the design, fabrication, and erection of such yurt.
- B. Installation Qualifications: Minimum of two years experience in erecting similar yurt.
- C. Source Limitations: Provide each type of product from a single manufacturing source to ensure uniformity.

1.5 PRE-INSTALLATION CONFERENCE

- A. Convene a conference approximately two weeks before scheduled commencement of the Work. Attendees shall include Facilities Management Design and Construction (FMDC) Administrator, Architect, Contractor, and trades involved. Agenda shall include schedule, responsibilities, critical path items and approvals.

1.6 DELIVERY, STORAGE, AND HANDLING

- A. Store and handle in strict compliance with manufacturer's written instructions and recommendations.
- B. Protect from damage due to weather, excessive temperature, and construction operations.

1.7 WARRANTY:

- A. Provide a manufacturer's standard limited warranty unless otherwise indicated.
- B. Provide a one-year warranty against defects in materials, workmanship, and installation.
- C. Provide a ten-year warranty for the vinyl sides.
- D. Provide a fifteen-year warranty for the Duro-last top.

PART 2 - PRODUCTS

2.1 MANUFACTURERS: Basis of design or approved equals

- A. Secret Creek (formerly known as Colorado Yurt), <https://coloradoyurt.com/>
- B. Pacific Yurt, <https://www.yurts.com/>
- C. Alaska Structures, <https://alaskastructures.com/>
- D. Yurts of America, <https://yurtsofamerica.com/>

2.2 MATERIALS:

- A. All components shall be included at minimum as shown on detailed on the drawings. Yurt supplier and installer to coordinate and verify sizes will work with design engineering requirements.

2.3 SUBSTITUTIONS:

- A. Comparable products of other manufacturers will be considered. Refer to section 006325 PRODUCT SUBSTITUTION REQUEST.

2.4 COMPONENTS:

- A. Lattice wall
- B. Rafters
- C. Center ring
- D. Exterior entry door & frame
- E. Tinted acrylic dome
- F. Tension cable
- G. Side cover
- H. Wall insulation
- I. Vinyl double pane sliding windows
- J. Top cover
- K. Roof insulation
- L. Rain diverter
- M. Hardware
- N. Snow and wind kit with standard hardware
- O. Perimeter blocking
- P. 2x6 rafter, ring, hardware upgrade
- Q. Fan support
- R. Instructions

2.5 FINISHES

- A. Fabric vinyl colors to be selected from standard colors provided by manufacturer.

PART 3 - EXECUTION

3.1 EXAMINATION

- A. Do not begin installation until substrates have been properly constructed and prepared

- B. If substrate is the responsibility of another installer, notify Architect in writing of the unsatisfactory preparation before proceeding.

3.2 PREPARATION

- A. Clean surfaces thoroughly prior to installation.
- B. Prepare surfaces using the methods recommended by the manufacturer for achieving the best result for the substrate under the project conditions.

3.3 INSTALLATION

- A. Install in accordance with manufacturer's instructions, approved submittals, and in proper relationship with adjacent construction.

3.4 FIELD QUALITY CONTROL

- A. Field Inspection: Coordinate field inspection in accordance with appropriate sections in Division 01.
- B. Manufacturer's Services: Coordinate manufacturer's services in accordance with appropriate sections in Division 01.

3.5 CLEANING AND PROTECTION

- A. Clean products in accordance with the manufacturer's recommendations.
- B. Touch-up, repair or replace damaged products before Substantial Completion.

END OF SECTION 133130

SECTION 321216 – ASPHALT PAVING

PART 1 – GENERAL

1.01 SUMMARY

- A. This Section includes the following:
 - 1. Hot-mix asphalt paving.
 - 2. Hot-mix asphalt patching.
 - 3. Hot-mix asphalt overlays.
 - 4. Asphalt surface treatments:
 - 5. Pavement-marking paint.
 - 6. Hot-mix asphalt curbs.
 - 7. Wheel stops.

1.02 SYSTEM DESCRIPTION

- A. Provide hot-mix asphalt pavement according to the materials, workmanship, and other applicable requirements of the standard specifications of the state or of authorities having jurisdiction.

1.03 SUBMITTALS

- A. Product Data: For each product specified. Include technical data and tested physical and performance properties.
- B. Job-Mix Designs: Certification, by authorities having jurisdiction, of approval of each job mix proposed for the Work.
- C. Job-Mix Designs: For each job mix proposed for the Work.
- D. Shop Drawings: Indicate pavement markings, lane separations, and defined parking spaces. Indicate dedicated handicapped spaces with international graphics symbol.
- E. Samples: 12 by 12 inches minimum, of paving fabric.
- F. Qualification Data: For firms and persons specified in the "Quality Assurance" Article to demonstrate their capabilities and experience. Include lists of completed projects with project names and addresses, names and addresses of engineers and owners, and other information specified.
- G. Material Test Reports: Indicate and interpret test results for compliance of materials with requirements indicated.
- H. Material Certificates: Certificates signed by manufacturers certifying that each material complies with requirements.

1.04 QUALITY ASSURANCE

- A. Installer Qualifications: Engage an experienced installer who has completed hot-mix asphalt paving similar in material, design, and extent to that indicated for this Project and with a record of successful in-service performance.
- B. Manufacturer Qualifications: Engage a firm experienced in manufacturing hot-mix asphalt similar to that indicated for this Project and with a record of successful in-service performance.
- C. Testing Agency Qualifications: Demonstrate to Engineer's satisfaction, based on Engineer's evaluation of criteria conforming to ASTM D 3666, that the independent testing agency has the experience and capability to satisfactorily conduct the testing indicated without delaying the Work.
- D. Regulatory Requirements: Conform to applicable standards of authorities having jurisdiction for asphalt paving work on public property.
- E. Asphalt-Paving Publication: Comply with AI's "The Asphalt Handbook," except where more stringent requirements are indicated.
- F. Preinstallation Conference: Conduct conference at Project site to review methods and procedures related to asphalt paving including, but not limited to, the following:
 - 1. Review proposed sources of paving materials, including capabilities and location of plant that will manufacture hot-mix asphalt.
 - 2. Review condition of substrate and preparatory work performed by other trades.
 - 3. Review requirements for protecting paving work, including restriction of traffic during installation period and for remainder of construction period.
 - 4. Review and finalize construction schedule for paving and related work. Verify availability of materials, paving Installer's personnel, and equipment required to execute the Work without delays.
 - 5. Review inspection and testing requirements, governing regulations, and proposed installation procedures.
 - 6. Review forecasted weather conditions and procedures for coping with unfavorable conditions.

1.05 DELIVERY, STORAGE, AND HANDLING

- A. Deliver pavement-marking materials to Project site in original packages with seals unbroken and bearing manufacturer's labels containing brand name and type of material, date of manufacture, and directions for storage.
- B. Store pavement-marking materials in a clean, dry, protected location and within temperature range required by manufacturer. Protect stored materials from direct sunlight.

1.06 PROJECT CONDITIONS

- A. Environmental Limitations: Do not apply asphalt materials if substrate is wet or exces-

sively damp or if the following conditions are not met:

1. Prime and Tack Coats: Minimum surface temperature of 60 deg F (15.5 deg C).
 2. Slurry Coat: Comply with weather limitations of ASTM D 3910.
 3. Asphalt Base Course: Minimum surface temperature of 40 deg F (4 deg C) and rising at time of placement.
 4. Asphalt Surface Course: Minimum surface temperature of 60 deg F (15.5 deg C) at time of placement.
- B. Pavement-Marking Paint: Proceed with pavement marking only on clean, dry surfaces and at a minimum ambient or surface temperature of 40 deg F (4 deg C) for oil-based materials, 50 deg F (10 deg C) for water-based materials, and not exceeding 95 deg F (35 deg C).

PART 2 – PRODUCTS

2.01 AGGREGATES

- A. General: Use materials and gradations that have performed satisfactorily in previous installations.
- B. Coarse Aggregate: Sound; angular crushed stone; crushed gravel; or properly cured, crushed blast-furnace slag; complying with ASTM D 692.
- C. Fine Aggregate: Sharp-edged natural sand or sand prepared from stone; gravel, properly cured blast-furnace slag, or combinations thereof; complying with ASTM D 1073.
 1. For hot-mix asphalt, limit natural sand to a maximum of 20 percent by weight of the total aggregate mass.
- D. Mineral Filler: Rock or slag dust, hydraulic cement, or other inert material complying with ASTM D 242.

2.02 ASPHALT MATERIALS

- A. Asphalt Cement: ASTM D 3381 for viscosity-graded material; ASTM D 946 for penetration-graded material.
- B. Asphalt Cement: ASTM D 3381 for viscosity-graded material.
- C. Undersealing Asphalt: ASTM D 3141, pumping consistency.
- D. Prime Coat: ASTM D 2027; medium-curing cutback asphalt; MC-30, MC-70, or MC-250.
- E. Prime Coat: Asphalt emulsion prime coat material shall conform to Missouri Standard Specifications for Highway Construction, Section 408.
- F. Tack Coat: Asphalt emulsion tack coat material shall conform to Missouri Standard Specifications for Highway Construction, Section 409.

- G. Fog Seal: ASTM D 977, emulsified asphalt or ASTM D 2397, cationic emulsified asphalt, slow setting, factory diluted in water, of suitable grade and consistency for application.
- H. Water: Potable.

2.03 AUXILIARY MATERIALS

- A. Herbicide: Commercial chemical for weed control, registered by Environmental Protection Agency (EPA). Provide granular, liquid, or wettable powder form.
- B. Sand: ASTM D 1073, Grade Nos. 2 or 3.
- C. Paving Geotextile: Nonwoven polypropylene, specifically designed for paving applications, resistant to chemical attack, rot, and mildew.
- D. Pavement-Marking Paint: Alkyd-resin type, ready-mixed, complying with FS TT-P-115, Type I, or AASHTO M-248, Type N.
- E. Pavement-Marking Paint: Latex, water-base emulsion, ready-mixed, complying with FS TT-P-1952.
- F. Glass Beads: AASHTO M-247.
- G. Wheel Stops: Precast, air-entrained concrete, 2500-psi minimum compressive strength, approximately 6 inches high, 9 inches wide, and 84 inches long. Provide chamfered corners and drainage slots on underside, and provide holes for anchoring to substrate.
 - 1. Dowels: Galvanized steel, diameter 3/4 inch, minimum length 10 inches.

2.04 MIXES

- A. Hot-Mix Asphalt: Provide dense, hot-laid, hot-mix asphalt plant mixes approved by authorities having jurisdiction; designed according to procedures in AI's "Mix Design Methods for Asphalt Concrete and Other Hot-Mix Types"; and complying with the following requirements:
 - 1. Provide mixes with a history of satisfactory performance in geographical area where Project is located.
 - 2. Base Course: As indicated.
 - 3. Surface Course: As indicated.
- B. Hot-Mix Asphalt: Provide dense, hot-laid, hot-mix asphalt plant mixes approved by authorities having jurisdiction and designed according to procedures in AI's "Mix Design Methods for Asphalt Concrete and Other Hot-Mix Types."
 - 1. Provide mixes with a history of satisfactory performance in geographical area where Project is located.
 - 2. Provide mixes complying with the composition, grading, and tolerance requirements of ASTM D 3515 for the following nominal, maximum aggregate sizes:

- a. Base Course: 1 inch.
- b. Surface Course: 1/2 inch.

PART 3 – EXECUTION

3.01 EXAMINATION

- A. Verify that subgrade is dry and in suitable condition to support paving and imposed loads.
- B. Proof-roll subbase using heavy, pneumatic-tired rollers to locate areas that are unstable or that require further compaction.
- C. Notify Engineer in writing of any unsatisfactory conditions. Do not begin paving installation until these conditions have been satisfactorily corrected.

3.02 COLD MILLING

- A. Clean existing paving surface of loose and deleterious material immediately before cold milling. Remove existing asphalt pavement, including hot-mix asphalt and, as necessary, unbound-aggregate base course, by cold milling to grades and cross sections indicated.
 - 1. Repair or replace curbs, manholes, and other construction damaged during cold milling.

3.03 PATCHING AND REPAIRS

- A. Patching: Saw cut perimeter of patch and excavate existing pavement section to sound base. Recompact new subgrade. Excavate rectangular or trapezoidal patches, extending 12 inches into adjacent sound pavement, unless otherwise indicated. Cut excavation faces vertically.
 - 1. Tack coat faces of excavation and allow to cure before paving.
 - 2. Fill excavation with dense-graded, hot-mix asphalt base mix and, while still hot, compact flush with adjacent surface.
 - 3. Partially fill excavation with dense-graded, hot-mix asphalt base mix and compact while still hot. Cover asphalt base course with compacted, hot-mix surface layer finished flush with adjacent surfaces.
- B. Portland Cement Concrete Pavement: Break cracked slabs and roll as required to reseal concrete pieces firmly.
 - 1. Pump hot undersealing asphalt under rocking slabs until slab is stabilized or, if necessary, crack slab into pieces and roll to reseal pieces firmly.
 - 2. Remove disintegrated or badly broken pavement. Prepare and patch with hot-mix asphalt.
- C. Leveling Course: Install and compact leveling course consisting of dense-graded, hot-mix asphalt surface course to level sags and fill depressions deeper than 1 inch in existing pavements.

1. Install leveling wedges in compacted lifts not exceeding 3 inches thick.
- D. Crack and Joint Filling: Remove existing filler material from cracks or joints to a depth of 1/4 inch. Refill with asphalt joint-filling material to restore watertight condition. Remove excess filler that has accumulated near cracks or joints.
- E. Tack Coat: Apply uniformly to existing surfaces of previously constructed asphalt or portland cement concrete paving and to surfaces abutting or projecting into new, hot-mix asphalt pavement. Apply at a uniform rate of 0.05 to 0.15 gal./sq. yd. of surface.
1. Allow tack coat to cure undisturbed before paving.
 2. Avoid smearing or staining adjoining surfaces, appurtenances, and surroundings. Remove spillages and clean affected surfaces.

3.04 SURFACE PREPARATION

- A. General: Immediately before placing asphalt materials, remove loose and deleterious material from substrate surfaces. Ensure that prepared subgrade is ready to receive paving.
1. Sweep loose granular particles from surface of unbound-aggregate base course. Do not dislodge or disturb aggregate embedded in compacted surface of base course.
- B. Herbicide Treatment: Apply herbicide according to manufacturer's recommended rates and written application instructions. Apply to dry, prepared subgrade or surface of compacted-aggregate base before applying paving materials.
1. Mix herbicide with prime coat when formulated by manufacturer for that purpose.
- C. Prime Coat: Apply uniformly over surface of compacted-aggregate base at a rate of 0.15 to 0.50 gal./sq. yd. Apply enough material to penetrate and seal, but not flood, surface. Allow prime coat to cure for 72 hours minimum.
1. If prime coat is not entirely absorbed within 24 hours after application, spread sand over surface to blot excess asphalt. Use just enough sand to prevent pickup under traffic. Remove loose sand by sweeping before pavement is placed and after volatiles have evaporated.
 2. Protect primed substrate from damage until ready to receive paving.

3.05 GEOTEXTILE INSTALLATION

- A. Apply bond coat, consisting of asphalt cement, uniformly to existing surfaces at a rate of 0.20 to 0.30 gal./sq. yd.
- B. Place paving geotextile promptly according to manufacturer's written instructions. Broom or roll geotextile smooth and free of wrinkles and folds. Overlap longitudinal joints 4 inches and transverse joints 6 inches.
1. Protect paving geotextile from traffic and other damage and place overlay paving the same day.

3.06 HOT-MIX ASPHALT PLACING

- A. Machine place hot-mix asphalt mix on prepared surface, spread uniformly, and strike off. Place asphalt mix by hand to areas inaccessible to equipment in a manner that prevents segregation of mix. Place each course to required grade, cross section, and thickness, when compacted.
 - 1. Place hot-mix asphalt base course in number of lifts and thicknesses indicated.
 - 2. Place hot-mix asphalt surface course in single lift.
 - 3. Spread mix at minimum temperature of 250 deg F.
 - 4. Begin applying mix along centerline of crown for crowned sections and on high side of one-way slopes, unless otherwise indicated.
 - 5. Regulate paver machine speed to obtain smooth, continuous surface free of pulls and tears in asphalt-paving mat.
- B. Place paving in consecutive strips not less than 10 feet wide, except where infill edge strips of a lesser width are required.
 - 1. After first strip has been placed and rolled, place succeeding strips and extend rolling to overlap previous strips. Complete asphalt base course for a section before placing asphalt surface course.
- C. Promptly correct surface irregularities in paving course behind paver. Use suitable hand tools to remove excess material forming high spots. Fill depressions with hot-mix asphalt to prevent segregation of mix; use suitable hand tools to smooth surface.

3.07 JOINTS

- A. Construct joints to ensure continuous bond between adjoining paving sections. Construct joints free of depressions with same texture and smoothness as other sections of hot-mix asphalt course.
 - 1. Clean contact surfaces and apply tack coat.
 - 2. Offset longitudinal joints in successive courses a minimum of 6 inches.
 - 3. Offset transverse joints in successive courses a minimum of 24 inches.
 - 4. Construct transverse joints by bulkhead method or sawed vertical face method as described in AI's "The Asphalt Handbook."
 - 5. Compact joints as soon as hot-mix asphalt will bear roller weight without excessive displacement.
 - 6. Compact asphalt at joints to a density within 2 percent of specified course density.

3.08 COMPACTION

- A. General: Begin compaction as soon as placed hot-mix paving will bear roller weight

without excessive displacement. Compact hot-mix paving with hand tampers or vibratory-plate compactors in areas inaccessible to rollers.

1. Complete compaction before mix temperature cools to 185 deg F.
- B. Breakdown Rolling: Accomplish breakdown or initial rolling immediately after rolling joints and outside edge. Examine surface immediately after breakdown rolling for indicated crown, grade, and smoothness. Repair surfaces by loosening displaced material, filling with hot-mix asphalt, and rerolling to required elevations.
- C. Intermediate Rolling: Begin intermediate rolling immediately after breakdown rolling, while hot-mix asphalt is still hot enough to achieve specified density. Continue rolling until hot-mix asphalt course has been uniformly compacted to the following density:
 1. Average Density: 96 percent of reference laboratory density according to ASTM D 1559, but not less than 94 percent nor greater than 100 percent.
 2. Average Density: 92 percent of reference maximum theoretical density according to ASTM D 2041, but not less than 90 percent nor greater than 96 percent.
- D. Finish Rolling: Finish roll paved surfaces to remove roller marks while hot-mix asphalt is still warm.
- E. Edge Shaping: While surface is being compacted and finished, trim edges of pavement to proper alignment. Bevel edges while still hot, with back of rake or smooth iron. Compact thoroughly using tamper or other satisfactory method.
- F. Repairs: Remove paved areas that are defective or contaminated with foreign materials. Remove paving course over area affected and replace with fresh, hot-mix asphalt. Compact by rolling to specified density and surface smoothness.
- G. Protection: After final rolling, do not permit vehicular traffic on pavement until it has cooled and hardened.
- H. Erect barricades to protect paving from traffic until mixture has cooled enough not to become marked.

3.09 INSTALLATION TOLERANCES

- A. Thickness: Compact each course to produce the thickness indicated within the following tolerances:
 1. Base Course: Plus or minus 1/2 inch.
 2. Surface Course: Plus 1/4 inch, no minus.
- B. Surface Smoothness: Compact each course to produce a surface smoothness within the following tolerances as determined by using a 10-foot straightedge applied transversely or longitudinally to paved areas:
 1. Base Course: 1/4 inch.
 2. Surface Course: 1/8 inch.

3. Crowned Surfaces: Test with crowned template centered and at right angle to crown. Maximum allowable variance from template is 1/4 inch.

3.10 ASPHALT CURBS

- A. Construct hot-mix asphalt curbs over compacted pavement surfaces. Apply a light tack coat, unless pavement surface is still tacky and free from dust. Spread mix at minimum temperature of 250 deg F.
 1. Asphalt Mix: Same as pavement surface-course mix.
- B. Place hot-mix asphalt to curb cross section indicated or, if not indicated, to local standard shapes, by machine or by hand in wood or metal forms. Tamp hand-placed materials and screed to smooth finish. Remove forms after hot-mix asphalt has cooled.

3.11 SURFACE TREATMENTS

- A. Fog Seals: Apply fog seal at a rate of 0.10 to 0.15 gal./sq. yd. to existing asphalt pavement and allow to cure. Lightly dust areas receiving excess fog seal with a fine sand.
- B. Slurry Seals: Apply slurry coat in a uniform thickness according to ASTM D 3910 and allow to cure.
 1. Roll slurry seal to smooth ridges and provide a uniform, smooth surface.

3.12 PAVEMENT MARKING

- A. Do not apply pavement-marking paint until layout, colors, and placement have been verified with Engineer.
- B. Allow paving to cure for 30 days before starting pavement marking.
- C. Sweep and clean surface to eliminate loose material and dust.
- D. Apply paint with mechanical equipment to produce pavement markings of dimensions indicated with uniform, straight edges. Apply at manufacturer's recommended rates to provide a minimum wet film thickness of 15 mils.
 1. Broadcast glass spheres uniformly into wet pavement markings at a rate of 6 lb/gal.

3.13 WHEEL STOPS

- A. Securely attach wheel stops into pavement with not less than 2 steel rebar dowels embedded in precast concrete at one-third points. Firmly bond each dowel to wheel stop and to pavement.
 1. Extend upper portion of dowel 5 inches into wheel stop and lower portion a minimum of 5 inches into pavement.

3.14 FIELD QUALITY CONTROL

- A. Testing Agency: Contractor will engage a qualified independent testing agency to perform field inspections and tests and to prepare test reports.

1. Testing agency will conduct and interpret tests and state in each report whether tested Work complies with or deviates from specified requirements.
- B. Additional testing, at Contractor's expense, will be performed to determine compliance of corrected Work with specified requirements.
- C. Thickness: In-place compacted thickness of hot-mix asphalt courses will be determined according to ASTM D 3549.
- D. Surface Smoothness: Finished surface of each hot-mix asphalt course will be tested for compliance with smoothness tolerances.
- E. In-Place Density: Samples of uncompacted paving mixtures and compacted pavement will be secured by testing agency according to ASTM D 979.
 1. Reference laboratory density will be determined by averaging results from 4 samples of hot-mix asphalt-paving mixture delivered daily to site, prepared according to ASTM D 1559, and compacted according to job-mix specifications.
 2. Reference maximum theoretical density will be determined by averaging results from 4 samples of hot-mix asphalt-paving mixture delivered daily to site, prepared according to ASTM D 2041, and compacted according to job-mix specifications.
 3. In-place density of compacted pavement will be determined by testing core samples according to ASTM D 1188 or ASTM D 2726.
 - a. One core sample will be taken for every 1000 sq. yd. or less of installed pavement, but in no case will fewer than 3 cores be taken.
 - b. Field density of in-place compacted pavement may also be determined by nuclear method according to ASTM D 2950 and correlated with ASTM D 1188 or ASTM D 2726.
- F. Remove and replace or install additional hot-mix asphalt where test results or measurements indicate that it does not comply with specified requirements.

3.15 WAYBILLS AND DELIVERY TICKETS

- A. Submit waybills and delivery tickets to onsite Resident Project Representative daily during the progress of work.

END OF SECTION 321216

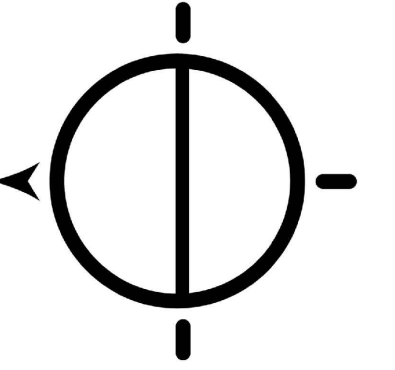
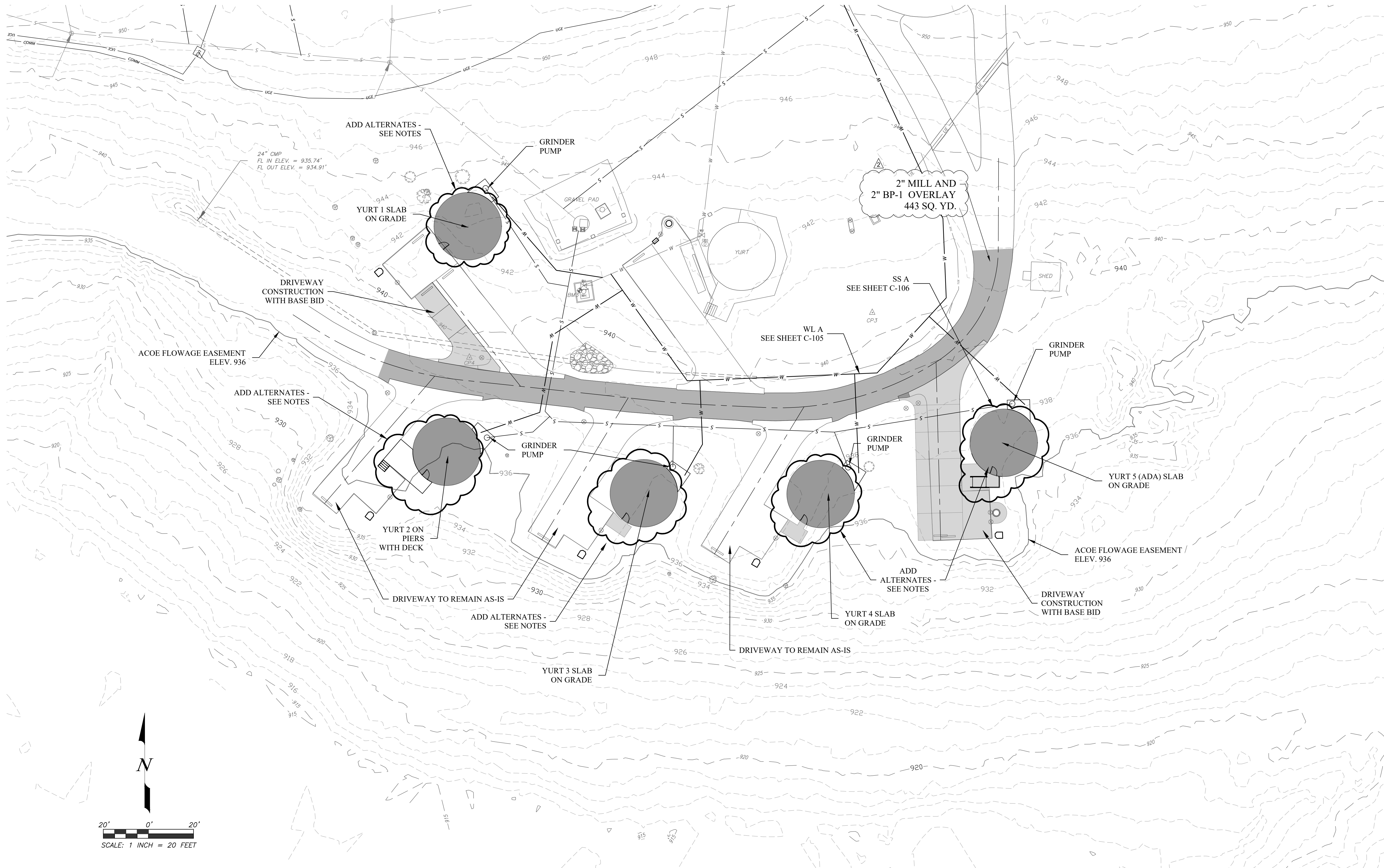

Missouri State Certificate of Authority Numbers:
Engineering: 2000156885; Land Surveying: 2001011476;
Landscape Architecture: 2007013673

OFFICE OF ADMINISTRATION
DIVISION OF FACILITIES
MANAGEMENT,
DESIGN AND CONSTRUCTION

DEPARTMENT OF
NATURAL RESOURCES
MISSOURI STATE PARKS

TABLE ROCK STATE PARK
REPLACE 5 BASIC SITES
WITH 5 PREMIUM YURTS

TABLE ROCK STATE PARK
CAMPGROUND #2
5272 STATE HWY 165
BRANSON, MISSOURI 65616

PROJECT # X2215-01
SITE # 5603
ASSET # 03018

REVISION: REV. 2 - ADDENDUM 2
DATE: 04/27/2023
REVISION: _____
DATE: _____
REVISION: _____
DATE: _____
ISSUE DATE: JANUARY 17, 2023

CAD DWG FILE: X2215-01_C-102
DRAWN BY: ALW
CHECKED BY: DAL
DESIGNED BY: ALW

SHEET TITLE:
SITE PLAN

SHEET NUMBER:

C-102

6 OF 32 SHEETS
01/17/2023

NOTE

1. BASE BID INCLUDES ALL SITE WORK, DRIVEWAY REPLACEMENT/EXPANSION, AND UTILITIES.
2. ADD ALTERNATE #1 INCLUDES DECK MATERIAL AND CONCRETE SLABS FOR YURT FOUNDATIONS AS WELL AS YURT UTILITY SERVICE ROUGH-INS. SEE MEP PLANS FOR DETAILS.
3. ADD ALTERNATE #2 INCLUDES THE BASE YURT STRUCTURE AND MATERIAL. SEE ARCHITECTURAL PLANS FOR DETAILS.
4. ADD ALTERNATE #3 INCLUDES THE INTERIOR FIXTURES AND FINISHES FOR THE YURTS. SEE ARCHITECTURAL PLANS FOR DETAILS.

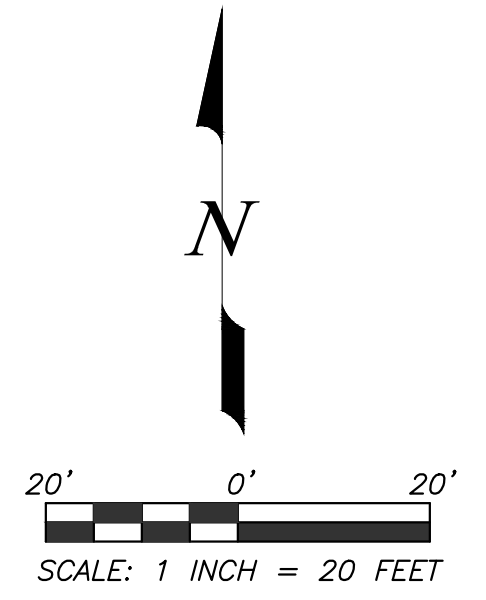

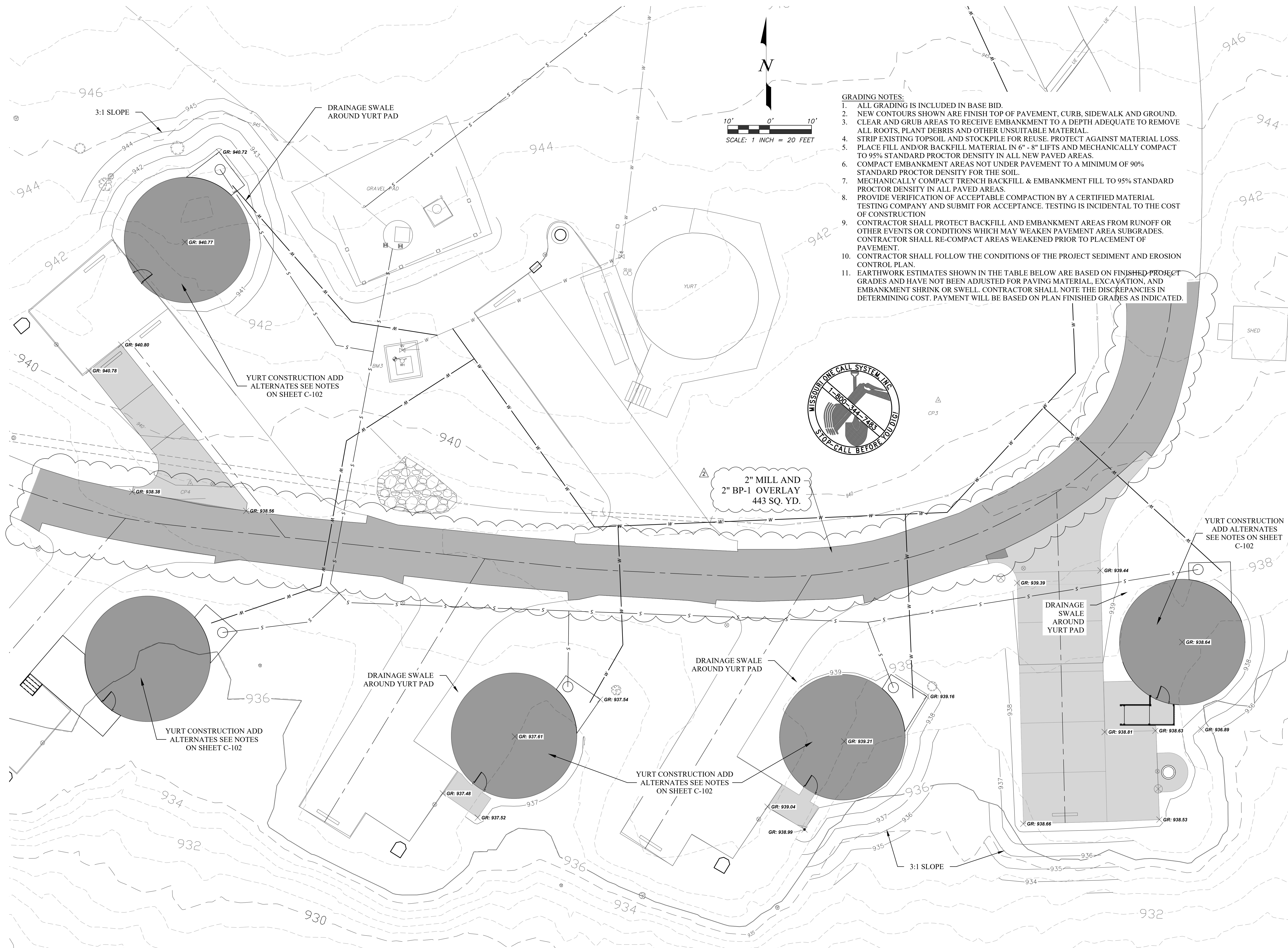

- GRADING NOTES:**
1. ALL GRADING IS INCLUDED IN BASE BID.
 2. NEW CONTOURS SHOWN ARE FINISH TOP OF PAVEMENT, CURB, SIDEWALK AND GROUND.
 3. CLEAR AND GRUB AREAS TO RECEIVE EMBANKMENT TO A DEPTH ADEQUATE TO REMOVE ALL ROOTS, PLANT DEBRIS AND OTHER UNSUITABLE MATERIAL.
 4. STRIP EXISTING TOPSOIL AND STOCKPILE FOR REUSE. PROTECT AGAINST MATERIAL LOSS.
 5. PLACE FILL AND/OR BACKFILL MATERIAL IN 6" - 8" LIFTS AND MECHANICALLY COMPACT TO 95% STANDARD PROCTOR DENSITY IN ALL NEW PAVED AREAS.
 6. COMPACT EMBANKMENT AREAS NOT UNDER PAVEMENT TO A MINIMUM OF 90% STANDARD PROCTOR DENSITY FOR THE SOIL.
 7. MECHANICALLY COMPACT TRENCH BACKFILL & EMBANKMENT FILL TO 95% STANDARD PROCTOR DENSITY IN ALL PAVED AREAS.
 8. PROVIDE VERIFICATION OF ACCEPTABLE COMPACTION BY A CERTIFIED MATERIAL TESTING COMPANY AND SUBMIT FOR ACCEPTANCE. TESTING IS INCIDENTAL TO THE COST OF CONSTRUCTION.
 9. CONTRACTOR SHALL PROTECT BACKFILL AND EMBANKMENT AREAS FROM RUNOFF OR OTHER EVENTS OR CONDITIONS WHICH MAY WEAKEN PAVEMENT AREA SUBGRADES. CONTRACTOR SHALL RE-COMPACT AREAS WEAKENED PRIOR TO PLACEMENT OF PAVEMENT.
 10. CONTRACTOR SHALL FOLLOW THE CONDITIONS OF THE PROJECT SEDIMENT AND EROSION CONTROL PLAN.
 11. EARTHWORK ESTIMATES SHOWN IN THE TABLE BELOW ARE BASED ON FINISHED PROJECT GRADES AND HAVE NOT BEEN ADJUSTED FOR PAVING MATERIAL, EXCAVATION, AND EMBANKMENT SHRINK OR SWELL. CONTRACTOR SHALL NOTE THE DISCREPANCIES IN DETERMINING COST. PAYMENT WILL BE BASED ON PLAN FINISHED GRADES AS INDICATED.

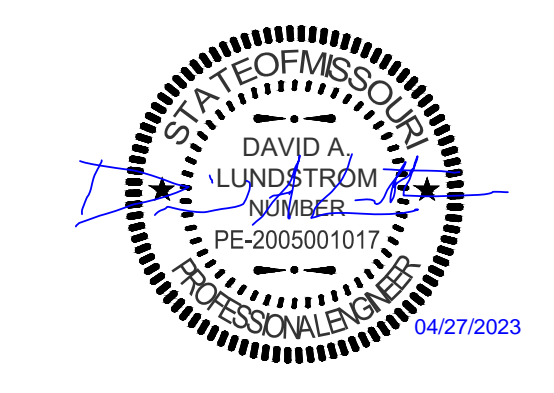

OFFICE OF ADMINISTRATION
DIVISION OF FACILITIES
MANAGEMENT,
DESIGN AND CONSTRUCTION

DEPARTMENT OF
NATURAL RESOURCES
MISSOURI STATE PARKS

TABLE ROCK STATE PARK
REPLACE 5 BASIC SITES
WITH 5 PREMIUM YURTS

TABLE ROCK STATE PARK
CAMPGROUND #2
5272 STATE HWY 165
BRANSON, MISSOURI 65616

PROJECT # X2215-01
SITE # 5603
ASSET # 03018

REVISION: REV. 2 - ADDENDUM 2
DATE: 04/27/2023
REVISION: _____
DATE: _____
REVISION: _____
DATE: _____
ISSUE DATE: JANUARY 17, 2023

CAD DWG FILE: X2215-01_C-102
DRAWN BY: ALW
CHECKED BY: DAL
DESIGNED BY: ALW

SHEET TITLE:
SITE GRADING PLAN

SHEET NUMBER:
C-103
7 OF 32 SHEETS
01/17/2023

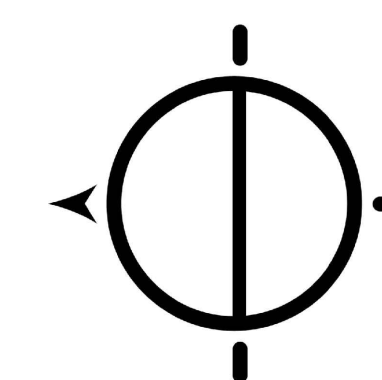
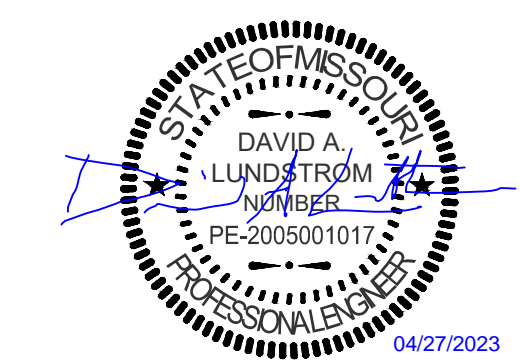

Missouri State Certificate of Authority Numbers:
Engineering: 2000158885, Land Surveying: 2001011476,
Landscape Architecture: 2007013673

OFFICE OF ADMINISTRATION
DIVISION OF FACILITIES
MANAGEMENT,
DESIGN AND CONSTRUCTION

DEPARTMENT OF
NATURAL RESOURCES
MISSOURI STATE PARKS

TABLE ROCK STATE PARK
REPLACE 5 BASIC SITES
WITH 5 PREMIUM YURTS

TABLE ROCK STATE PARK
CAMPGROUND #2
5272 STATE HWY 165
BRANSON, MISSOURI 65616

PROJECT # X2215-01
SITE # 5603
ASSET # 03018

REVISION: REV. 2 - ADDENDUM 2
DATE: 04/27/2023
REVISION: _____
DATE: _____
REVISION: _____
DATE: _____
ISSUE DATE: 01/17/2023

CAD DWG FILE: X2215-01_C-004
DRAWN BY: WSH
CHECKED BY: CMW
DESIGNED BY: WSH

SHEET TITLE:
SEWER DETAILS

SHEET NUMBER:

C-503

13 OF 32 SHEETS
JANUARY 17, 2023

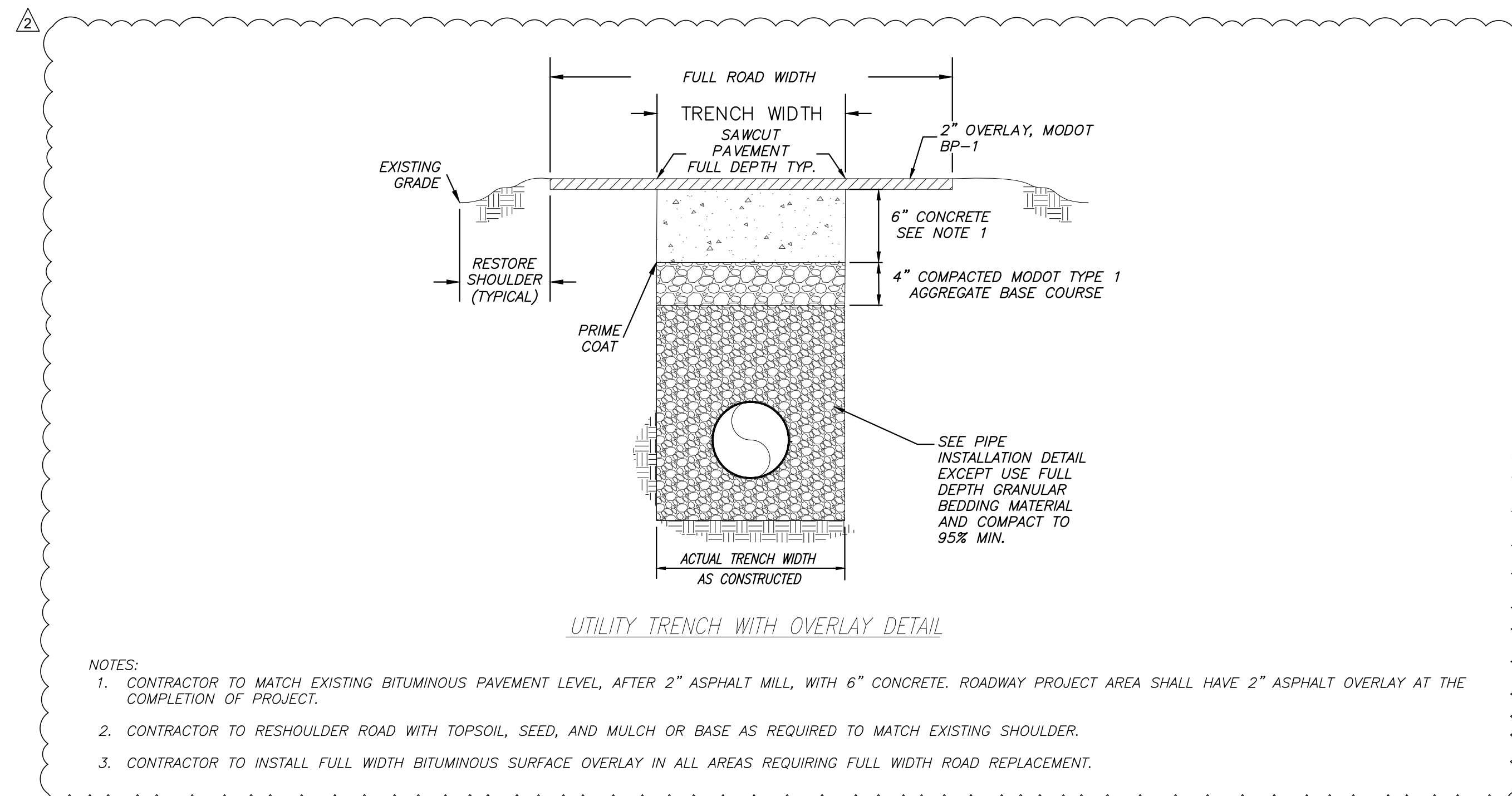

- NOTES:
- CONTRACTOR TO MATCH EXISTING BITUMINOUS PAVEMENT LEVEL, AFTER 2" ASPHALT MILL, WITH 6" CONCRETE. ROADWAY PROJECT AREA SHALL HAVE 2" ASPHALT OVERLAY AT THE COMPLETION OF PROJECT.
 - CONTRACTOR TO RESHOULDER ROAD WITH TOPSOIL, SEED, AND MULCH OR BASE AS REQUIRED TO MATCH EXISTING SHOULDER.
 - CONTRACTOR TO INSTALL FULL WIDTH BITUMINOUS SURFACE OVERLAY IN ALL AREAS REQUIRING FULL WIDTH ROAD REPLACEMENT.

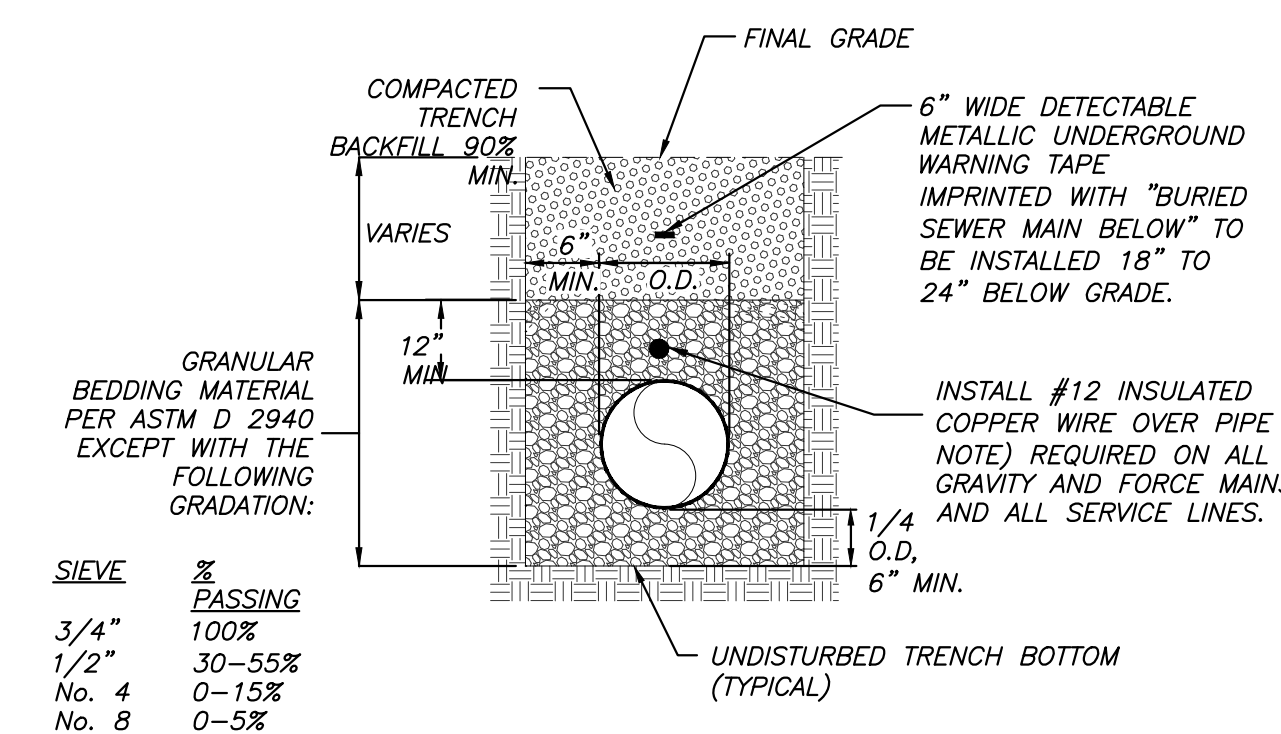
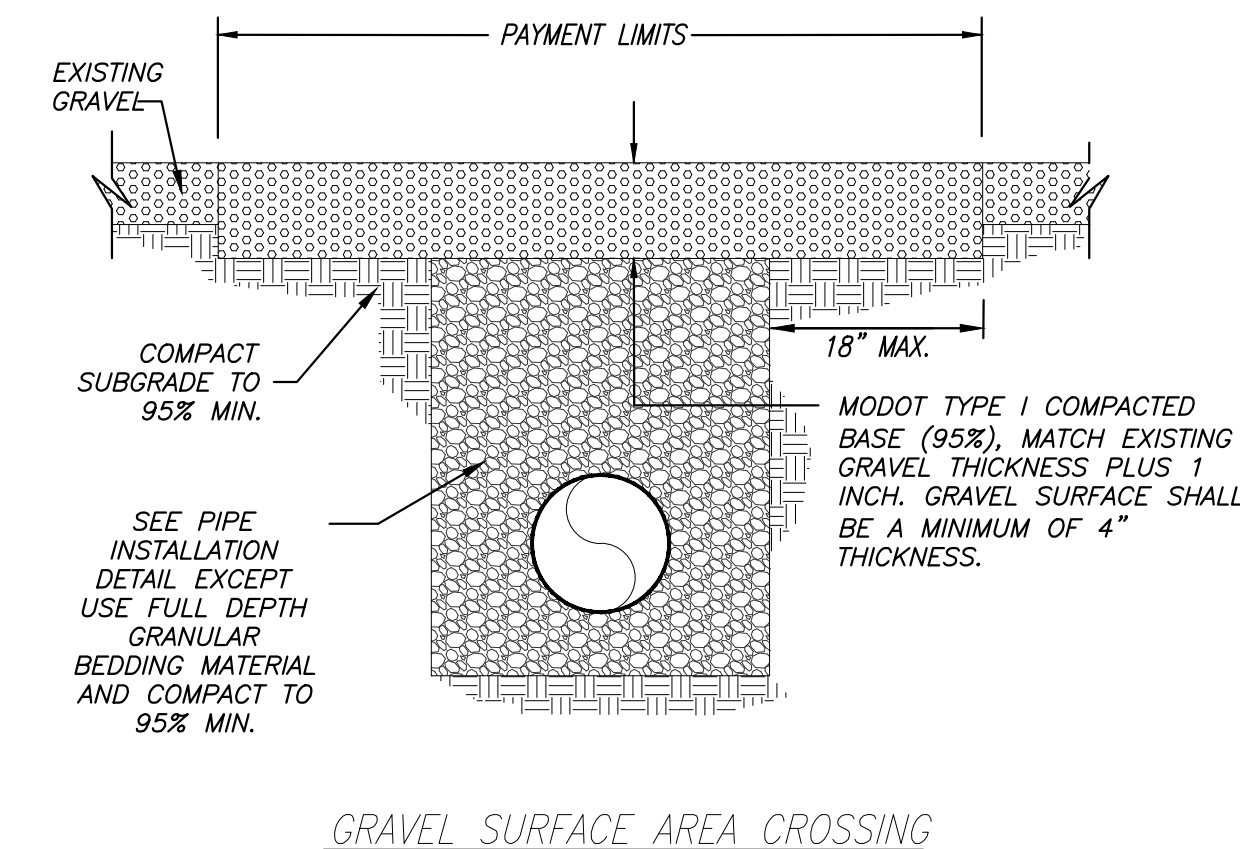
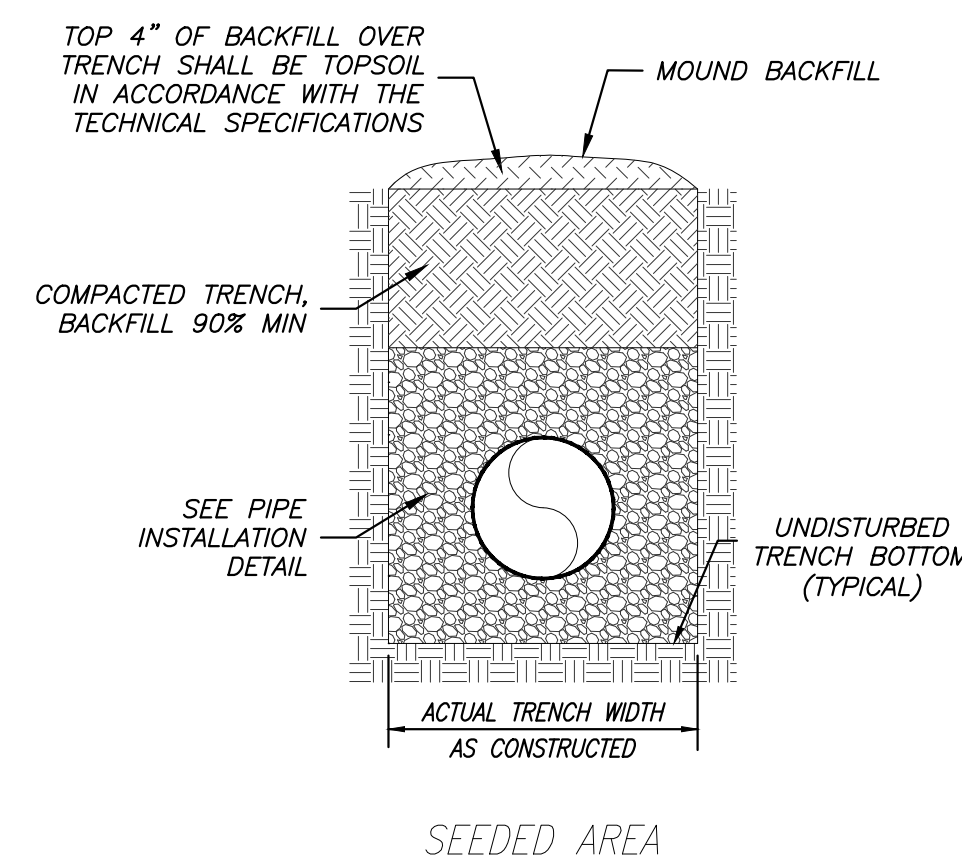

SIEVE	% PASSING
3/4"	100%
1/2"	30-55%
No. 4	0-15%
No. 8	0-5%

SINGLE PIPE IN TRENCH
PIPE INSTALLATION DETAIL
NOT TO SCALE

NOTE:
ENDS OF LOCATOR WIRE SHALL BE PLACED IN A 6" DIP RISER PIPE WITH CAST IRON LIDS AT 500' MIN. SPACING AND SHALL BE GROUNDED TO A 4x1/2" DIA. COPPER ROD AT RISERS. ALL WIRE SPLICES SHALL USE BRASS/COPPER SPLIT-BOLT CONNECTORS. RISERS AND GROUNDING RODS FOR LOCATION WIRE ON SERVICE LATERALS SHALL BE PLACED, AT A MINIMUM, AT ROW AND FINAL CLEANOUT LOCATION ON THE PROPERTY.

CARRIER PIPE DIA. (PVC)	CASING PIPE DIA. (STEEL)	MIN. WALL THICKNESS (IN.)
1 1/2"	4"	0.188
1 3/4"	4"	0.188
2"	4"	0.188
2 1/2"	4"	0.188
3"	6"	0.188
4"	10"	0.188
6"	12"	0.188
8"	14"	0.219
10"	16"	0.250
12"	20"	0.281
14"	24"	0.344
16"	24"	0.344
18"	30"	0.406
20"	30"	0.406
24"	36"	0.469

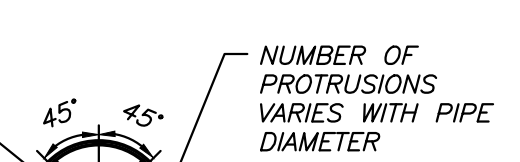
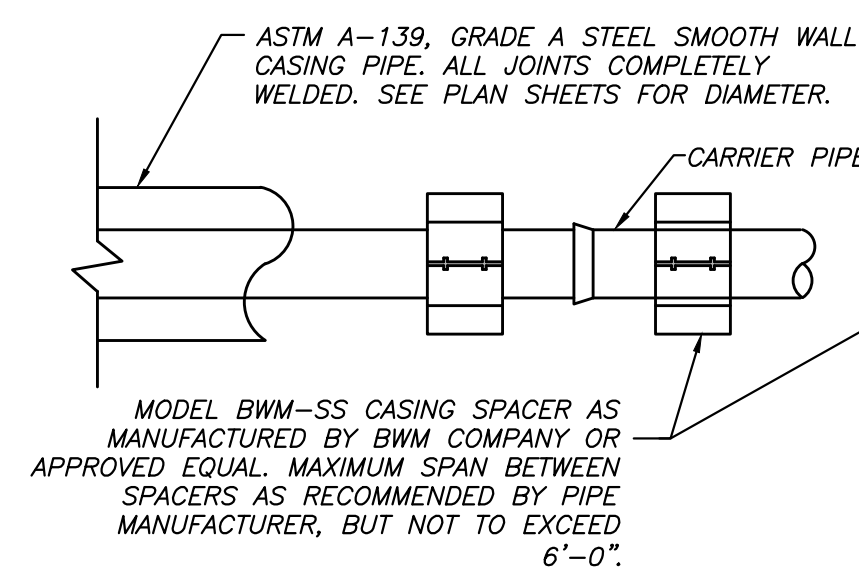
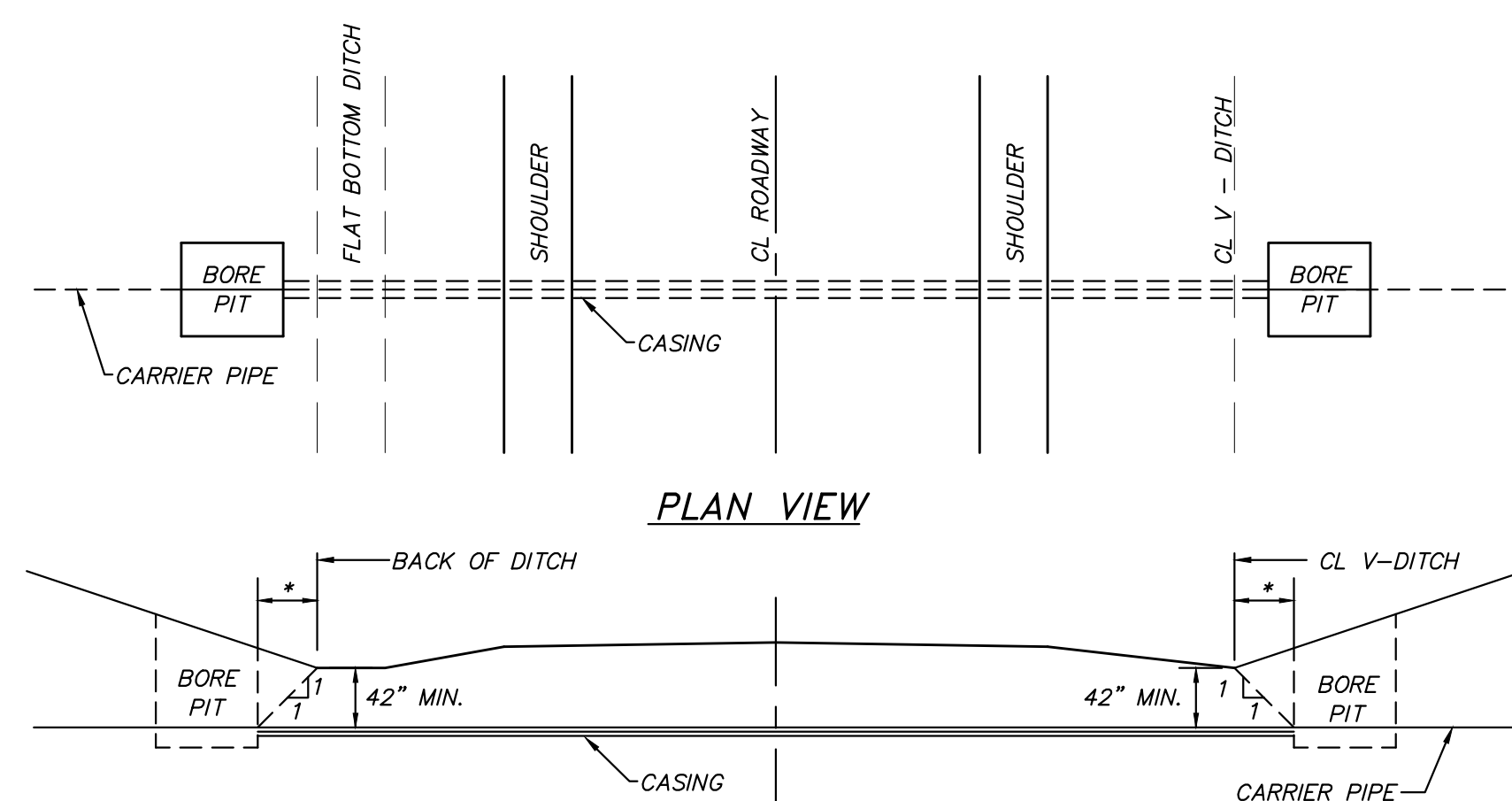

MODEL BWM-SS CASING SPACER AS MANUFACTURED BY BWM COMPANY OR APPROVED EQUAL. MAXIMUM SPAN BETWEEN SPACERS AS RECOMMENDED BY PIPE MANUFACTURER, BUT NOT TO EXCEED 6'-0".

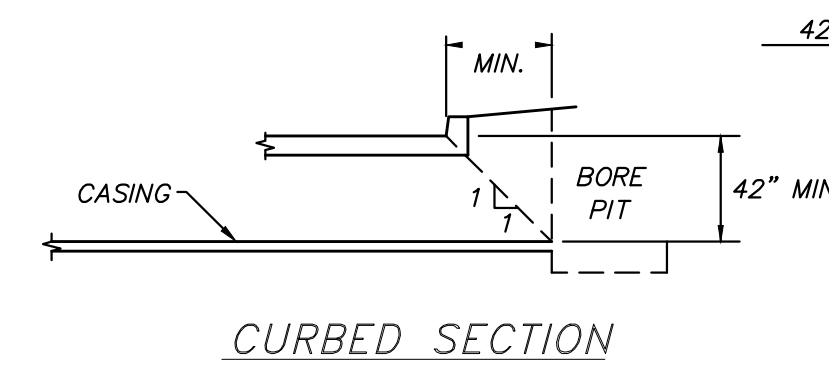

- NOTES:
- STEEL CASING REQUIRED.
 - EACH END OF CASING TO BE SEALED WITH END SEALS PROVIDED BY THE MANUFACTURER OF CASING SPACERS.
 - CASING SHALL BE INSTALLED SIMULTANEOUSLY W/BORING OPERATION. ALL AREAS DISTURBED DURING CONSTRUCTION AND TRENCHES SHALL BE COMPACTED, AND VEGETATED PER SPECIFICATIONS.

TYPICAL ROAD BORING DETAIL
NOT TO SCALE